

Model(型號): 電位器(旋轉式)-----R09A12H01

[▶ 下載PDF文檔](#)

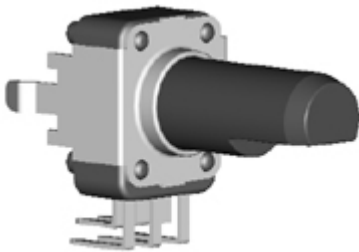

特點:

經過改良的防塵、防水設計，結構簡約，外徑只有9.8mm，是高密度的固定設計的理想之選。

作用:

適用於作為多種音頻產品、視頻產品、電子音樂器械等的調節裝置。

Dimensions(規格圖):

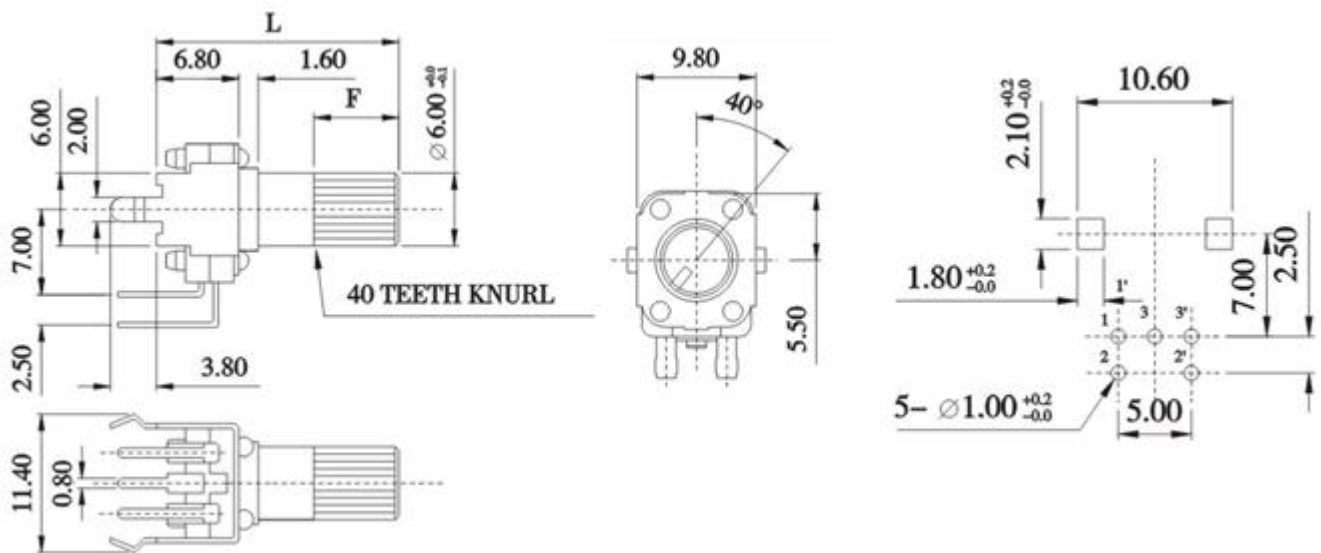

TYPE OF KNOB

F Type

L	15	20	25	30	35
F	6	7	12	12	12

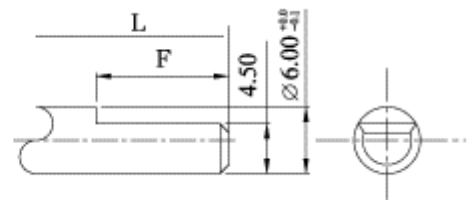

K Type

L	20	25	30	35
F	7	7	7	7

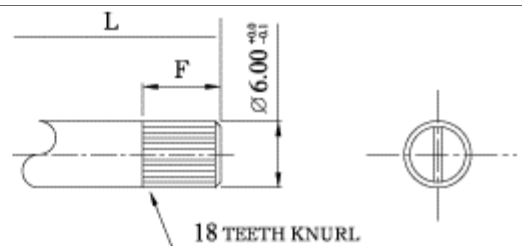

E Type

L	15	20	25	30	35
F	6	7	7	7	7

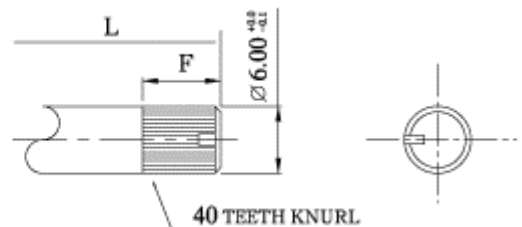

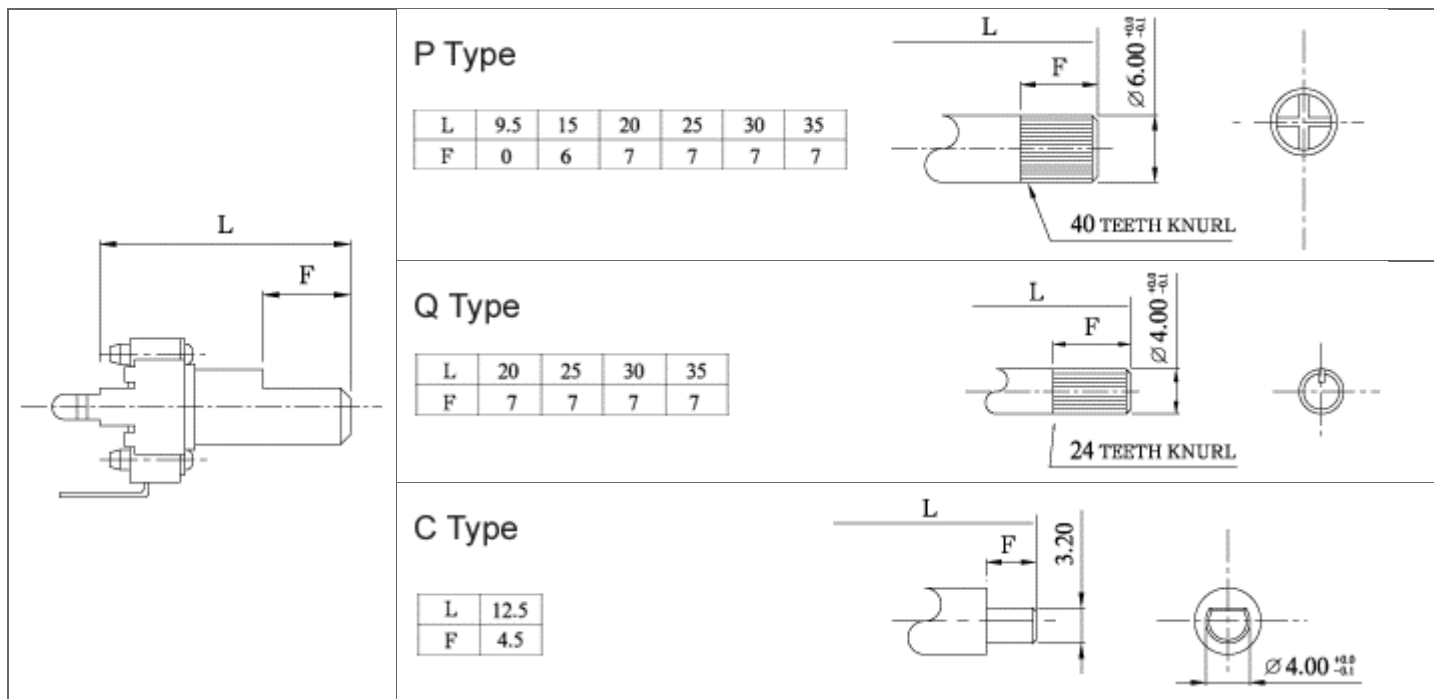

Specifications(規格)

Electrical Characteristics [電氣性能]

Total resistance [全阻抗值]	100Ω - 1MΩ
Total resistance tolerance [全阻抗值容許差]	±20%
Ratings power(w) [額定功率]	0.05W
Resistance taper [阻抗變化特性]	A,B, *C,D,W
Residual resistance [殘留阻值]	R < 5KΩ 10Ω Max. 5KΩ ≤ R ≤ 10KΩ 50Ω Max. 10KΩ < R ≤ 50KΩ 70Ω Max. 50KΩ < R ≤ 100KΩ 120Ω Max. 100KΩ < R ≤ 1MΩ 320Ω Max.
Sliding noise [滑動雜音]	100mV Max.
Withstanding voltage [耐電壓]	1 minute at AC 250V
Gang error [連動誤差]	-40dB ~ 0dB ±3dB Max.
Insulation resistance [絕緣阻抗]	100MΩ Min. at DC 100V.
Max. operating voltage [最高使用電壓]	AC 50V , DC 12V

Mechanical Characteristics [機械性能]

Operation torque [回轉力矩]	10~80gf . cm
Rotation stopper strength [止動強度]	3.0Kgf . cm Min.
Total rotational angle [回轉角度]	280 ±5°

Endurance Characteristics [耐久性能]

Rotational life [回轉壽命]	More than 10,000 cycles
------------------------	-------------------------