

Model(型號): 電位器(旋轉式)-----R11A11H01

[▶ 下載PDF文檔](#)

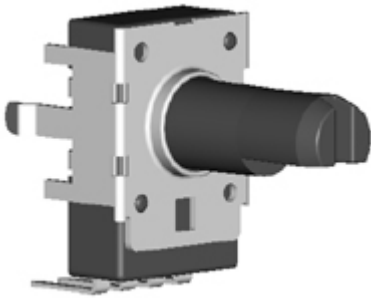

**特點:**  
是所有音頻產品的理想之選。

**作用:**  
是收音機、帶卡帶錄音的收音機、功放等的理想之選。

**Dimensions(規格圖):**

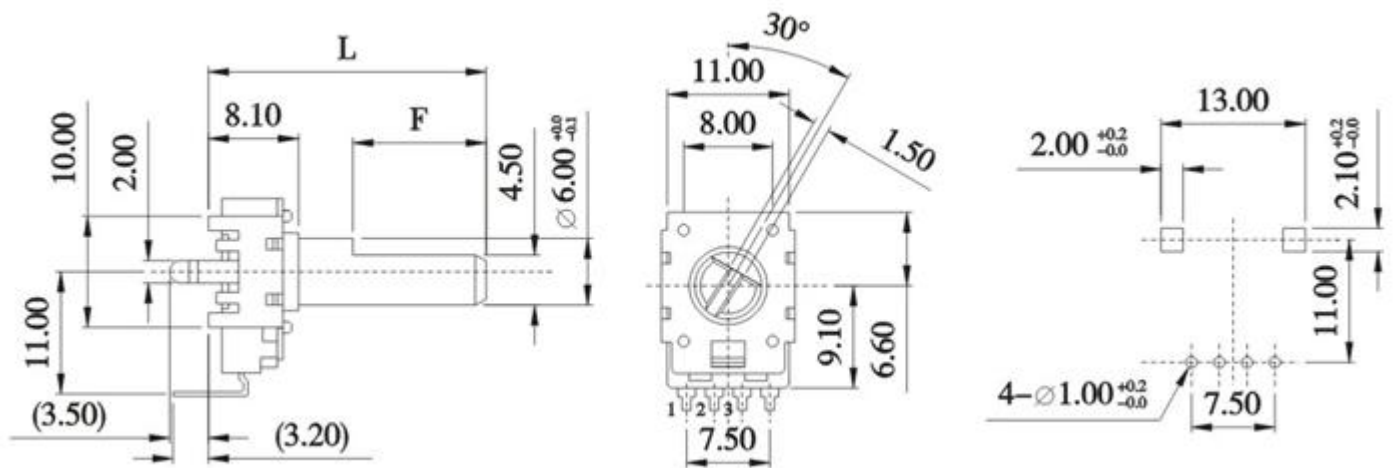

**SHAFT DIMENSION**

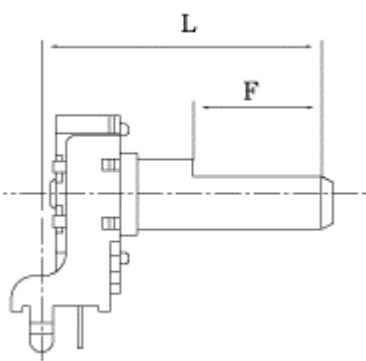

F Type

L	15	20	25	30	35
F	4.5	7	12	12	12

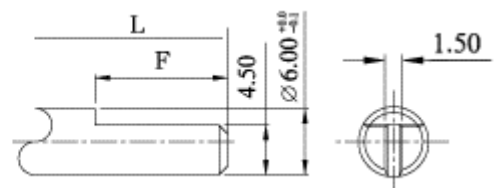

**Specifications(規格)**

**Electrical Characteristics [ 電氣性能 ]**

Total resistance [ 全阻抗值 ]	5KΩ-500KΩ
Total resistance tolerance [ 全阻抗值容許差 ]	±20%
Ratings power(w) [ 額定功率 ]	0.05W
Resistance taper [ 阻抗變化特性 ]	A,B, C,D,W
Residual resistance [ 殘留阻值 ]	R < 10KΩ            20Ω Max. 10KΩ < R ≤ 50KΩ   30Ω Max. 50KΩ < R ≤ 500KΩ 0.1% Max.
Sliding noise [ 滑動雜音 ]	100mV Max.
Withstanding voltage [ 耐電壓 ]	1 minute at AC 500V
Gang error [ 連動誤差 ]	-40dB ~ 0dB ±3dB Max.
Insulation resistance [ 絕緣阻抗 ]	100MΩ Min. at DC 500V.
Max. operating voltage [ 最高使用電壓 ]	AC 50V , DC 12V

<b>Mechanical Characteristics [ 機械性能 ]</b>	
Operation torque [ 回轉力矩 ]	30~200gf . cm
Rotation stopper strength [ 止動強度 ]	6.0Kgf . cm Min.
Total rotational angle [回轉角度]	300 ±5°
<b>Endurance Characteristics [ 耐久性能 ]</b>	
Rotational life [ 回轉壽命 ]	More than15,000 cycles

[Http://www.productwell.com](http://www.productwell.com) E-Mail: [pwtw@productwell.com](mailto:pwtw@productwell.com) TEL: 0769-81353212 FAX: 0769-81353211