

Model(型號): 電位器(旋轉式)-----R11A11HB1

[▶ 下載PDF文檔](#)

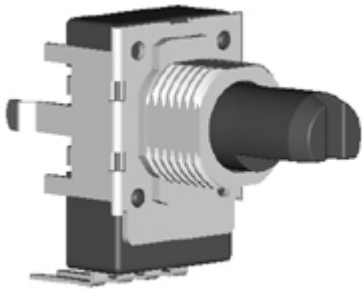

特點:
是所有音頻產品的理想之選。

作用:
是收音機、帶卡帶錄音的收音機、功放等的理想之選。

Dimensions(規格圖):

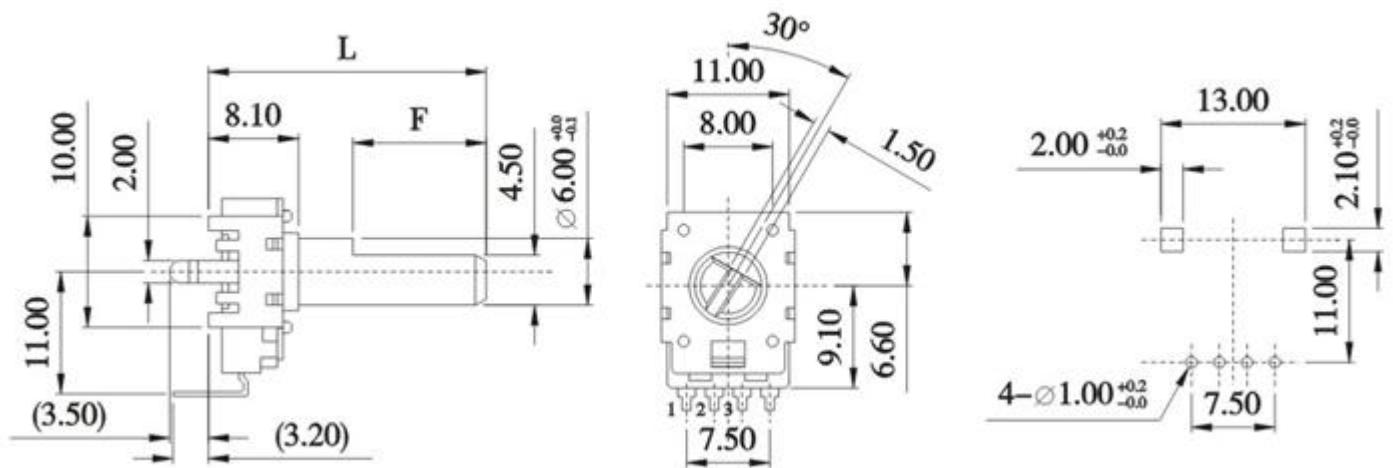

SHAFT DIMENSION

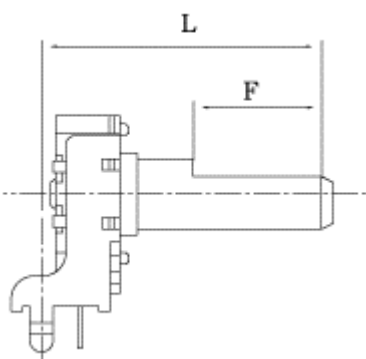

F Type

L	15	20	25	30	35
F	4.5	7	12	12	12

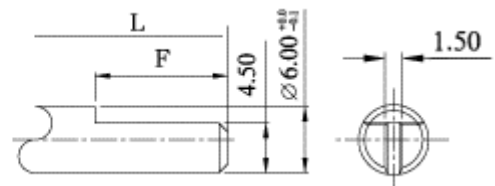

Specifications(規格)

Electrical Characteristics [電氣性能]

Total resistance [全阻抗值]	5KΩ-500KΩ
Total resistance tolerance [全阻抗值容許差]	±20%
Ratings power(w) [額定功率]	0.05W
Resistance taper [阻抗變化特性]	A,B, C,D,W
Residual resistance [殘留阻值]	R < 10KΩ 20Ω Max. 10KΩ < R ≤ 50KΩ 30Ω Max. 50KΩ < R ≤ 500KΩ 0.1% Max.
Sliding noise [滑動雜音]	100mV Max.
Withstanding voltage [耐電壓]	1 minute at AC 500V
Gang error [連動誤差]	-40dB ~ 0dB ±3dB Max.
Insulation resistance [絕緣阻抗]	100MΩ Min. at DC 500V.
Max. operating voltage [最高使用電壓]	AC 50V , DC 12V

Mechanical Characteristics [機械性能]

Operation torque [回轉力矩]	30~200gf . cm
Rotation stopper strength [止動強度]	6.0Kgf . cm Min.
Total rotational angle [回轉角度]	300 ±5°
Endurance Characteristics [耐久性能]	
Rotational life [回轉壽命]	More than15,000 cycles

[Http://www.productwell.com](http://www.productwell.com) E-Mail: pwtw@productwell.com TEL: 0769-81353212 FAX: 0769-81353211